

U-Block Profile

V-Block Profile

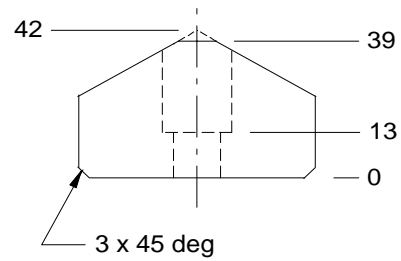
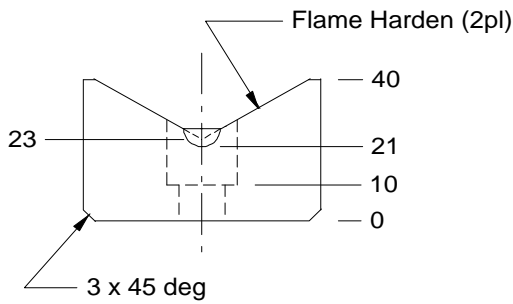

Materials: V-Block: Aluminum Bronze w/Graphite Plugs; U-Block: 4140 w/flame hardened wear surfaces

Tolerances: Between screw holes: +/- 0.12; Between dowel holes: +/- 0.10

Catalog Number		L	A	B	C	Mounting Holes
U-Block	V-Block					
G157515	G177515	150		100	125	2
G157520	G177520	200		150	175	2
G157525	G177525	250	125	200	225	3
G157530	G177530	300	150	250	275	3